

Analog Standard Cell

BG05A - CMOS Bandgap Voltage Reference

DATA SHEET

Process

C35 (0.35 μ m)

Description

The BG05A cell is a bandgap voltage reference with a constant output voltage of typically 1.21V.

Key Features

- Small Area 0.036 mm²
- Size x = 214 μ m, y = 167 μ m
- Supply Voltage 3.0 to 3.6V
- Junction Temp. Range -40 to 125°C
- Output Voltage 1.21V
- TK < 100ppm
- High PSFTP_{1kHz} > 86dB
- Power Down Mode

Symbol

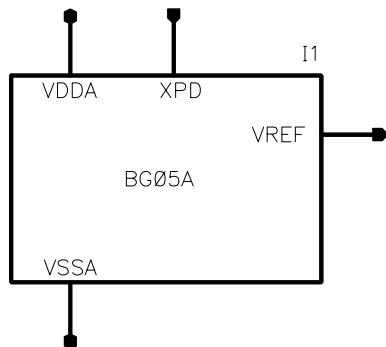

Pinlist

Pin	Description	Type
VREF	Output Voltage	Analog
XPD	Power Down not	Digital
VDDA	Positive Analog Supply Voltage	Supply
VSSA	Negative Analog Supply Voltage	Supply

TECHNICAL DATA FOR 3.3V SUPPLY(T_{junction} = –40 to 125°C, VDDA=+3.0V to +3.6V, C_L=1pF, R_L=10MΩ, unless otherwise specified)**GENERAL PARAMETERS**

Symbol	Parameter	Conditions	Min	Typ	Max	Unit
T _{junction}	Junction Temperature		-40	27	125	°C
X	X – Size of macro cell			214		μm
Y	Y – Size of macro cell			167		μm

REFERENCE CHARACTERISTICS

Symbol	Parameter	Conditions	Min	Typ	Max	Unit
VREF	Reference Voltage	27°C	1.11	1.21	1.31	V
TK ¹⁾	Temp. Coefficient	–30 to 120°C		40	100	ppm
TK _{nom}	Temp. Coefficient	27°C		0		ppm

AC PARAMETERS

Symbol	Parameter	Conditions	Min	Typ	Max	Unit
R _{out}	Output Resistance	1 kHz		2.2		Ω
PSFTP _{1Hz} ²⁾	Pos. Power Supply Feed Through	1Hz		–105		dB
PSFTP _{1kHz}	Pos. Power Supply Feed Through	1kHz		–86		dB
PSFTP _{100kHz}	Pos. Power Supply Feed Through	100kHz		–48		dB

NOISE PARAMETERS

Symbol	Parameter	Conditions	Min	Typ	Max	Unit
EOVN _{1Hz}	Equiv. Output Voltage Noise	1Hz		4		μV/√Hz
EOVN _{1kHz}	Equiv. Output Voltage Noise	1kHz		0.3		μV/√Hz
EOVN _{100kHz}	Equiv. Output Voltage Noise	100kHz		220		nV/√Hz
EOVN _{RMS}	Equiv. Output Voltage Noise RMS	1Hz – 10MHz		140		μVrms

1) Measured with Box-Method $TK = \frac{VREF_{max} - VREF_{min}}{T_{max} - T_{min}} \times \frac{1}{VREF_{@27^{\circ}C}} \times 10^6$ [ppm]

2) Defines the relative feed through of the power supply change to the reference voltage change in dB

$$\text{E.g.: } \Delta VREF = VREF \times \left(\frac{\Delta VDDA}{VDDA} \right) \times 10^{\left(\frac{PSFTP_{1Hz}}{20} \right)}$$

POWER REQUIREMENTS

Symbol	Parameter	Conditions	Min	Typ	Max	Unit
VDDA	Pos. Analog Supply Voltage		3.0	3.3	3.6	V
VSSA	Neg. Analog Supply Voltage		0	0	0	V
IDDA	Supply Current Analog			46	78	μA
P _{diss}	Power Consumption			152	281	μW
IDDA _{PD}	Power Down Supply Current Analog			0.04	23	nA
P _{diss_PD}	Power Down Power Consumption			0.13	82.8	nW

TRANSIENT PARAMETERS

Symbol	Parameter	Conditions	Min	Typ	Max	Unit
T _{wakeup} ¹⁾	Wakeup Time	VREF \pm 0.5%	5	20	700	μs
T _{startup_fast} ²⁾	Startup Time Fast	VREF \pm 0.5%	5	14	10000	μs
T _{startup_slow} ³⁾	Startup Time Slow	VREF \pm 0.5%	14	20	22500	μs

OUTPUT PARAMETERS

Symbol	Parameter	Conditions	Min	Typ	Max	Unit
I _{source} ⁴⁾	Source Current		70	275	500	μA
I _{sink} ⁴⁾	Sink Current		21	32	40	μA

-
- 1) Power down rise/fall time of 1ns
 - 2) Power supply rise time of 1 μs
 - 3) Power supply rise time of 10 μs
 - 4) Output source/sink current for a variation of VREF less than 1%

Contact

austriamicrosystems AG
A 8141 Schloss Premstätten, Austria
T. +43 (0) 3136 500 5333
F. +43 (0) 3136 500 5755
support@austriamicrosystems.com

Copyright

Copyright © 2004 austriamicrosystems. Trademarks registered ®. All rights reserved. The material herein may not be reproduced, adapted, merged, translated, stored, or used without the prior written consent of the copyright owner. To the best of its knowledge, austriamicrosystems asserts that the information contained in this publication is accurate and correct.